



www.calvaryportsmouth.co.uk

A dramatic sunset with a sky of orange, red, and yellow. In the foreground, an open book lies flat, its pages filled with text. The title 'The Greatest Journey in the World' is superimposed in large, bold, yellow letters with a black outline over the book and sky.

The Greatest Journey in the World

From the miracle of our origin to the mystery of our destiny

A dramatic sunset with a sky of orange, red, and yellow clouds. In the foreground, an open Bible lies flat, showing text on both pages. The text is partially obscured by the large yellow title. The overall mood is contemplative and spiritual.

Through The Bible Session 1 Genesis 1-3

From the miracle of our origin to the mystery of our destiny

The Panorama of History

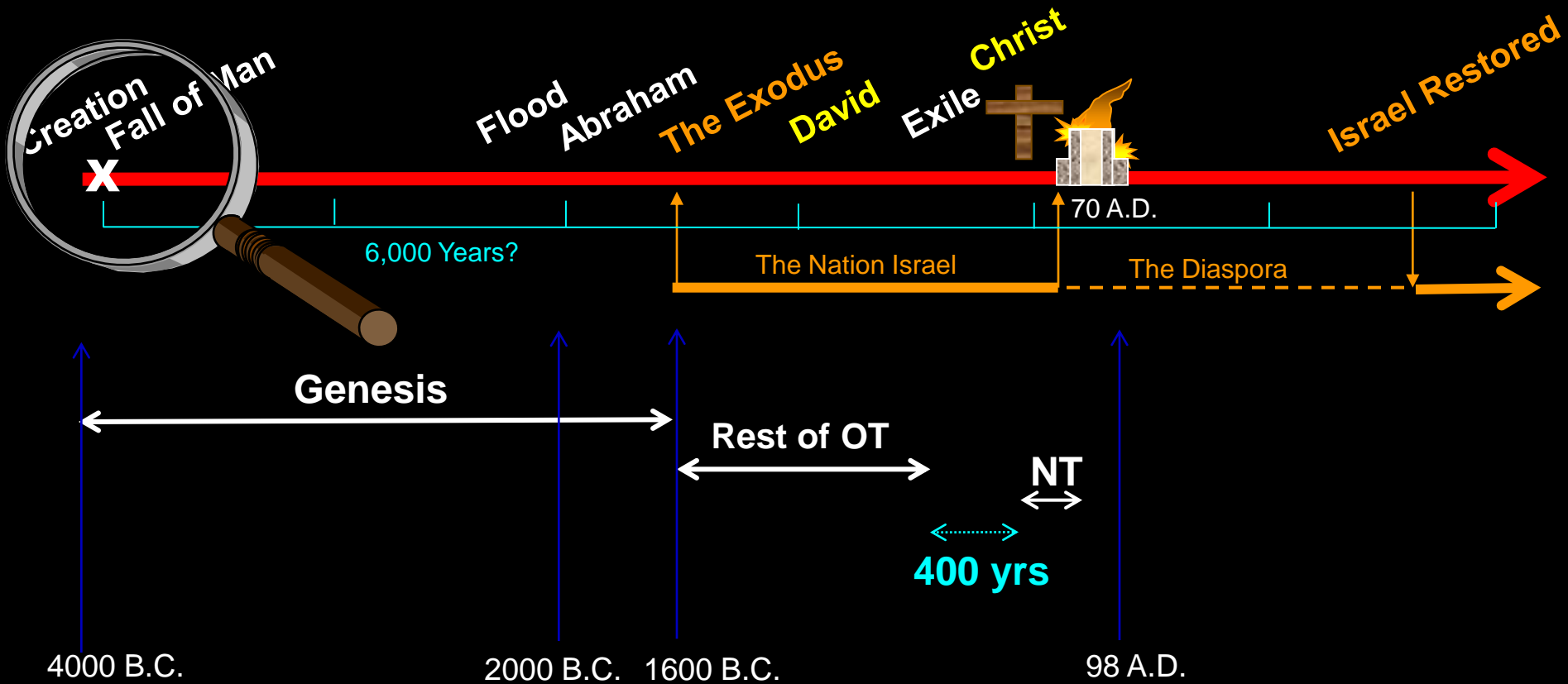

Beginnings

- Creation
- Man
- Woman
- Sabbath
- Marriage
- Home
- Childhood
- Sin
- Murder
- Sacrifice
- Grace
- Trade
- Agriculture
- City life
- Races
- Languages
- Chosen people
- ...etc.

Anticipates All False Philosophies

- Atheism Created by God
- Pantheism God is transcendent and distinguishable
- Polytheism One God
- Materialism Matter had a beginning
- Humanism God, not man, ultimate reality
- Evolutionism God created
- Uniformism God intervenes

All Major Doctrines

- Sovereign election
- Salvation
- Justification by faith
- Believer's Security
- Separation
- Disciplinary chastisement
- Divine Incarnation
- Rapture of the Church
- Death and Resurrection
- Priesthoods:
 - Aaronic
 - Melchizedek
- The Antichrist
- Palestinian Covenant

Genesis – The Foundation

If the foundations be destroyed, what can the righteous do?

Psalm 11:3

Following a major national poll...

“clearly shows that ...many have left the church because they no longer believe the Bible is the absolute Word of God”

Source: Ken Ham, Answers Update, Vol 13:11:2

Take God At His Word

All the words of my mouth are in righteousness; there is nothing **froward** or perverse in them. They are all **plain** to him that understandeth, and right to them that find knowledge.

Prov 8:8-9

פַּתַּל *Pathal*: froward, twisted

נִכּוֹחַ *Nakoach*: straightforward, uprightness

Session 1

In the beginning God created the heaven and the earth

בְּרֵאשִׁית בָּרָא אֱלֹהִים אֶת הַשָּׁמַיִם וְאֶת הָאָרֶץ:

Genesis 1:1

בְּרֵאשִׁית *Beresheet* = in beginning

בָּרָא *Bara* = create out of nothing
(*Asa* = make, fashion, fabricate)
(*Yatsa* = form)

אֱלֹהִים *Eloheim* = Plural noun, used as a singular

Christ on Every Page

In the beginning God created the heaven and the earth

בְּרֵאשִׁית בָּרָא אֱלֹהִים אֶת הַשָּׁמַיִם וְאֶת הָאָרֶץ:

Genesis 1:1

בְּרֵאשִׁית *Beresheet* = in beginning

בָּרָא *Bara* = create out of nothing
(*Asa* = make, fashion, fabricate)
(*Yatsa* = form)

אֱלֹהִים *Eloheim* = Plural noun, used as a singular

Light

1 In the beginning God created the heaven and the earth.

2 And the earth was without form, and void; and darkness was upon the face of the deep. And the Spirit of God moved upon the face of the waters.

3 And God said, Let there be light: and there was light.

4 And God saw the light, that it was good: and God divided the light from the darkness.

Light

Verse 3

And God said, Let there be light: and there was light.

וַיֹּאמֶר אֱלֹהִים יְהִי אוֹר וַיְהִי אוֹר

'owr hayah 'owr hayah Eloheim amar

light be light be Eloheim Said
(God)

Genesis 1:3

And God said, 'Let light be light'

And God said, 'Let The Light illuminate'

Light

- For the Light to now illuminate..
- It had to already exist

Light

⁶ For God, who commanded the light to shine out of darkness, hath shined in our hearts, to give the light of the knowledge of the glory of God in the face of Jesus Christ.

2 Cor 4:6

- Light was therefore pre-existent

Light

I form the light, and create darkness: I make peace, and create evil: I the LORD do all these things.

Isaiah 45:7

Light

I form the light, and **create** darkness: I make peace,
and create evil: I the LORD do all these things.

Isaiah 45:7

ברא

bara (create out of
nothing)

Light

I **form** the light, and **create** darkness: I make peace,
and create evil: I the LORD do all these things.

Isaiah 45:7

יצר yatsar

(mould into a form)

**KJV - earthen,
fashion, form,
frame, make, potter,
purpose.**

ברא

bara (create out of
nothing)

The Light of the world

¹² Then spake Jesus again unto them, saying:

I am the light of the world: he that followeth me shall not walk in darkness, but shall have the light of life.

John 8:12

The Light of the world

5 This then is the message which we have heard of him, and declare unto you, that **God is light**, and in him is no darkness at all.

1 John 1:5

The Light of the world

- Light was pre-existent in the person of Jesus Christ
- God commanded the Light to shine
- The Light simply then illuminated
- Jesus Christ – the pre-existent One – who is the Light, created all things

The Light of the world

- Light was pre-existent in the person of Jesus Christ
- God commanded the Light to shine
- The Light simply then illuminated
- Jesus Christ – the pre-existent One – who is the Light, created all things

Symmetry of Design

- Each particle has an antiparticle

particle + antiparticle  annihilation + photon

- Physicists suggest this is a reversible reaction
- The implication...
- Light could have created matter!

Creation Week

- Day One: Let Light illuminate
- 2nd Day: Stretching of Space
- 3rd Day: Land and vegetation
- 4th Day: Sun, Moon, Stars
- 5th Day: Sea animals & Birds
- 6th Day: Land animals & Man

Six Days?

- Did God really create in six literal 24 hour days?
- Your answer to this question is a measure of your maturity as a believer
- Do you trust God's Word or Man's opinion?
- Why couldn't God have created in six days?
- Why did He take so long?
- What does God say?

Let a man question the inspiration of the Scriptures and a curious, even monstrous, inversion takes place: thereafter he judges the Word instead of letting the Word judge him; he determines what the Word should teach instead of permitting it to determine what he should believe; he edits, amends, strikes out, adds at his pleasure; but always he sits above the Word and makes it amenable to him instead of kneeling before God and becoming amenable to the Word.

(Tozer, "The Wrath of God, What is it?",
"Man the Dwelling Place of God," chapter 26.)

Six Days?

Remember the sabbath day, to keep it holy. Six days shalt thou labour, and do all thy work: But the seventh day is the sabbath of the LORD thy God: in it thou shalt not do any work, thou, nor thy son, nor thy daughter, thy manservant, nor thy maidservant, nor thy cattle, nor thy stranger that is within thy gates: **For in six days the LORD made heaven and earth, the sea, and all that in them is,** and rested the seventh day: wherefore the LORD blessed the sabbath day, and hallowed it.

Six Days?

Wherefore the children of Israel shall keep the sabbath, to observe the sabbath throughout their generations, for a perpetual covenant. It is a sign between me and the children of Israel for ever: **for in six days the LORD made heaven and earth**, and on the seventh day he rested, and was refreshed. And he gave unto Moses, when he had made an end of communing with him upon mount Sinai, two tables of testimony, tables of stone, **written with the finger of God.**

Exodus 31:16-18

It's impossible for God to lie! - **Heb 6:18**



The Book of Genesis

Chapter 1

1 In the beginning God created the heaven and the earth.

2 And the earth was without form, and void; and darkness was upon the face of the deep. And the Spirit of God moved upon the face of the waters.

3 And God said, Let there be light: and there was light.

4 And God saw the light, that it was good: and God divided the light from the darkness.

5 And God called the light Day, and the darkness he called Night. And the evening and the morning were the first day [day one].

6 And God said, Let there be a firmament in the midst of the waters, and let it divide the waters from the waters.

7 And God made the firmament, and divided the waters which were under the firmament from the waters which were above the firmament: and it was so.

8 And God called the firmament Heaven. And the evening and the morning were the second day.

Genesis 1:6-8

9 And God said, Let the waters under the heaven be gathered together **unto one place,** and let the dry land appear: and it was so.

10 And God called the dry land Earth; and the gathering together of the waters called he Seas: and God saw that it was good.

Genesis 1:9-10

One Land Mass - Past



One Land Mass - Future

And there were voices, and thunders, and lightnings; and there was a great earthquake, such as was not since men were upon the earth, so mighty an earthquake, and so great... And every island fled away, and the mountains were not found.

Revelation 16:18-20

“Restitution of all things” Ref - Acts 3:21

9 And God said, Let the waters under the heaven be gathered together unto one place, and let the dry land appear: and it was so.

10 And God called the dry land Earth; and the gathering together of the waters called he Seas: and God saw that it was good.

Genesis 1:9-10

Radio Polonium Halos

“An exceedingly large number of polonium halos are embedded in granites around the world. Just as frozen Alka-Seltzer bubbles would be clear evidence of the quick-freezing of the water, so are these many polonium halos undeniable evidence that a sea of primordial matter quickly "froze" into solid granite. The occurrence of these polonium halos, then, distinctly implies that our earth was formed in a very short time, in complete harmony with the biblical record of creation.”

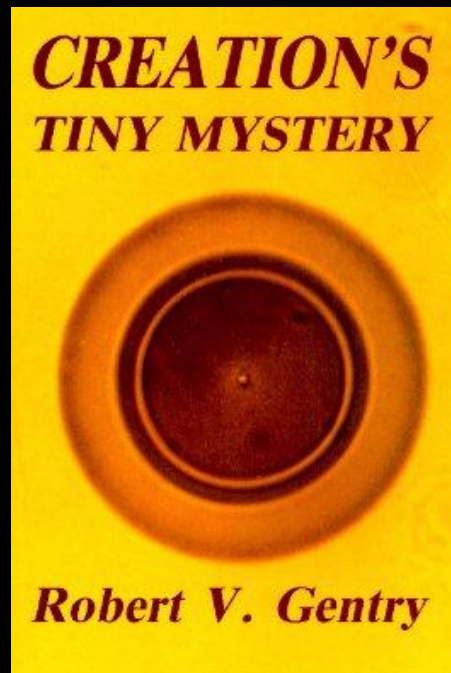

<http://www.halos.com>



Radio Polonium Halos

“Polonium microspheres — or halos — contradict the evolutionary belief that granites formed as hot magma and slowly cooled over millions of years. To the contrary, halos provide unambiguous evidence of both an almost instantaneous creation of granites and the young age of the earth.”

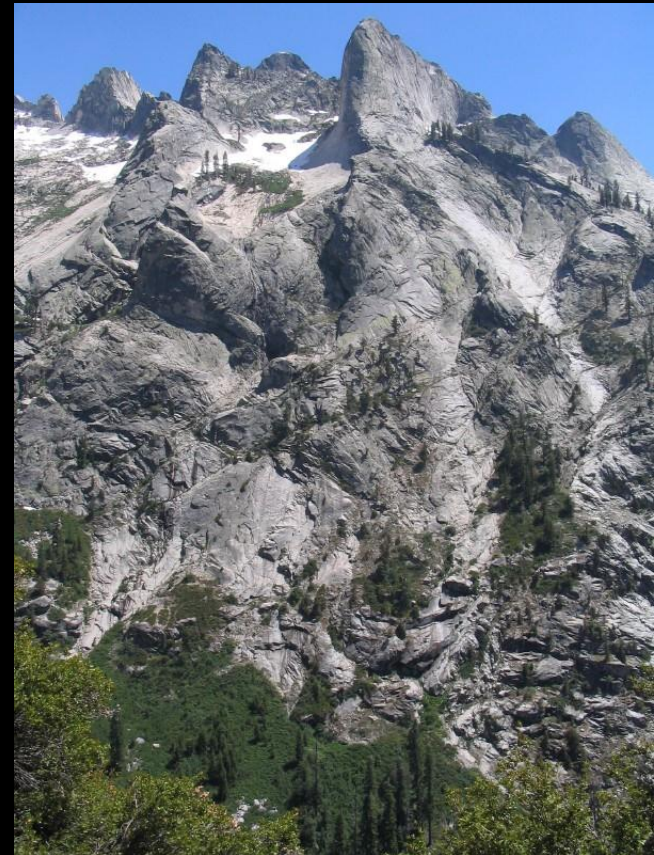

11 And God said, Let the earth bring forth grass, the herb yielding seed, and the fruit tree yielding fruit **after his kind,** whose seed is in itself, upon the earth: and it was so.

12 And the earth brought forth grass, and herb yielding seed **after his kind,** and the tree yielding fruit, whose seed was in itself, **after his kind:** and God saw that it was good.

13 And the evening and the morning were the third day.

After His Kind

Apple Pip?  Apple Tree

Orange Pip?  Orange Tree

Grain of Wheat?  Wheat

Sunflower Seed?  Sunflower

Strawberry Plant?  Strawberry

Banana Tree? 



“It is a truly wonderful fact... that all animals and all plants throughout all time and space should be related to each other...”

Charles Darwin

The Origin of Species by Means of Natural Selection or The Preservation of Favored Races in the Struggle for Life
Charles Darwin 1859 p. 170

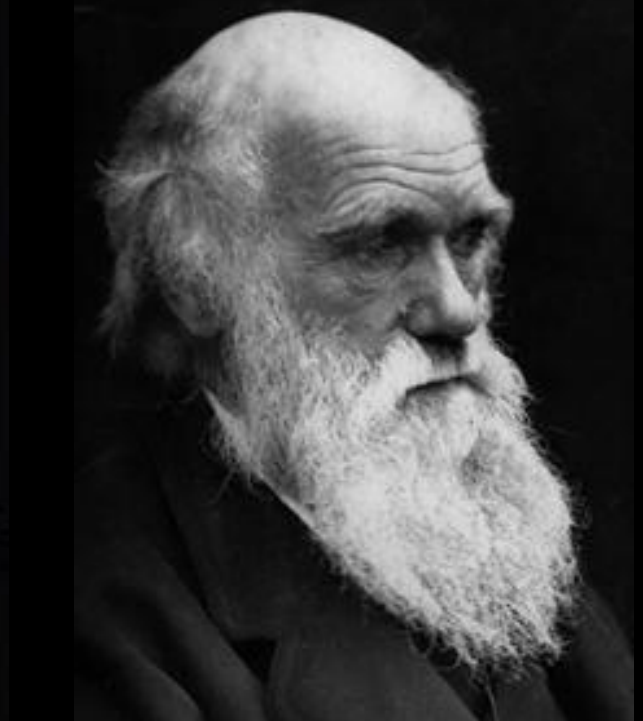

After His Kind



WARNING!
Seeds may
produce
frog!



Bible account & Evolution are opposites

Creation

Death only after Adam's sin →

Earth before the Sun →

Birds before land animals →

Chicken before egg →

Light before stars →

Earth made under the waters →

Everything 'after its kind' →

Everything fully formed →

Gradual decay →

Man made in God's
image →

Evolution

Death before Man

Sun before the Earth

Land animals before birds

Egg before chicken

Stars before light

Earth hot molten rock then rain
producing the oceans

Transitional forms

Basic form needing to develop

Gradual improvement

'god' made in man's
image

11 And God said, Let the earth bring forth grass, the herb yielding seed, and the fruit tree yielding fruit after his kind, whose seed is in itself, upon the earth: and it was so.

12 And the earth brought forth grass, and herb yielding seed after his kind, and the tree yielding fruit, whose seed was in itself, after his kind: and God saw that it was good.

13 And the evening and the morning were the third day.

A Simple Leaf?



Anatomy of a Leaf

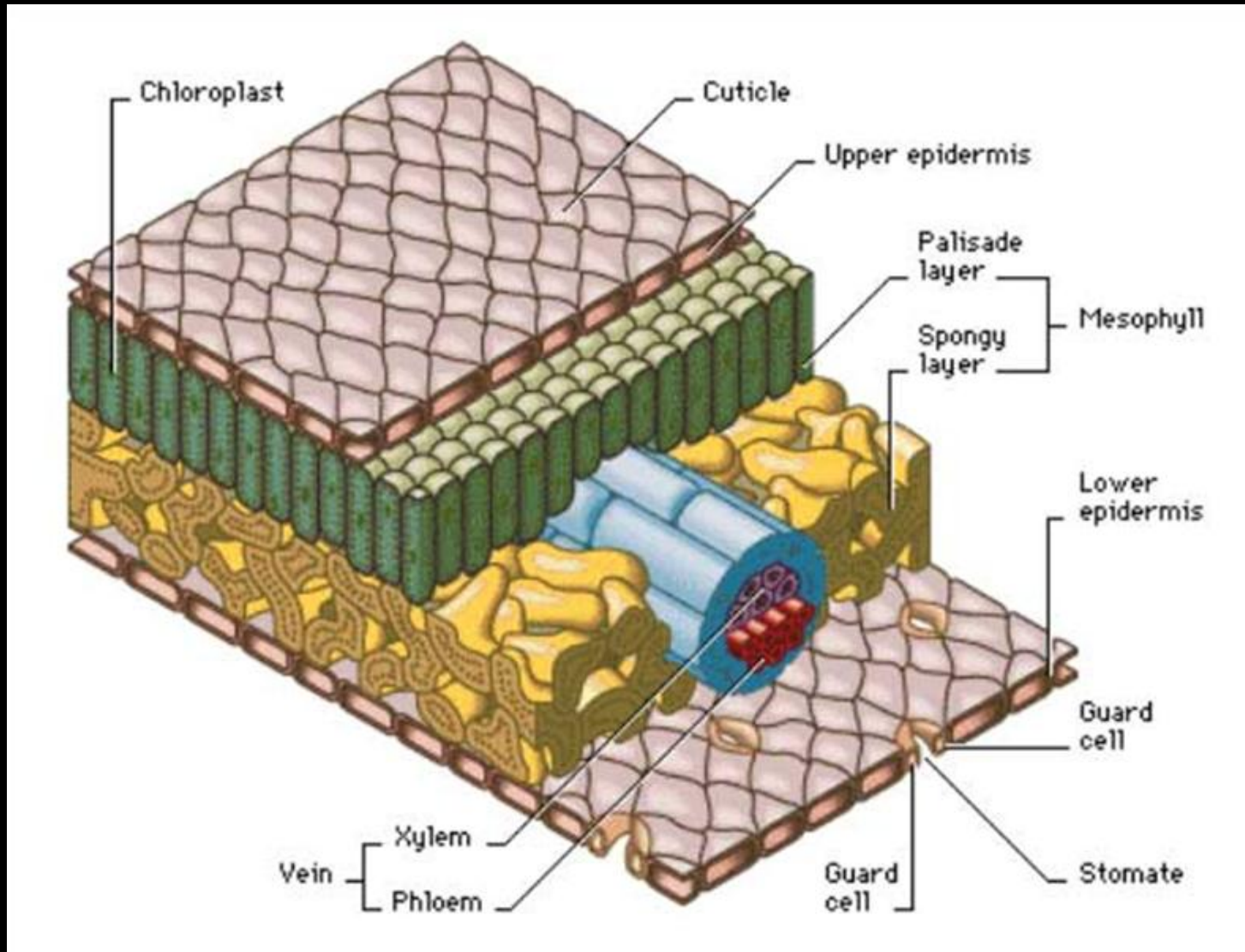

Photosynthesis

- Means “To build with light”:
 - Sugar factories producing millions of new glucose molecules/second

Photosynthesis

- Means “To build with light”:
 - Sugar factories producing millions of new glucose molecules/second
- Most plants produce more glucose than they use and store it as starch and other carbohydrates in roots, stems, and leaves.

Photosynthesis

- Means “To build with light”:
 - Sugar factories producing millions of new glucose molecules/second
- Most plants produce more glucose than they use and store it as starch and other carbohydrates in roots, stems, and leaves.
- Each year photosynthesizing organisms produce about 170 billion metric tons of extra carbohydrates, about 30 metric tons for every person on earth.

2 Stage Process

- The Light-Dependent Reaction

- A chloroplast traps light energy and converts it into chemical energy contained in two types of molecules

- nicotinamide adenine dinucleotide phosphate (NADP)
 - adenosine triphosphate (ATP)

Anatomy of a Leaf

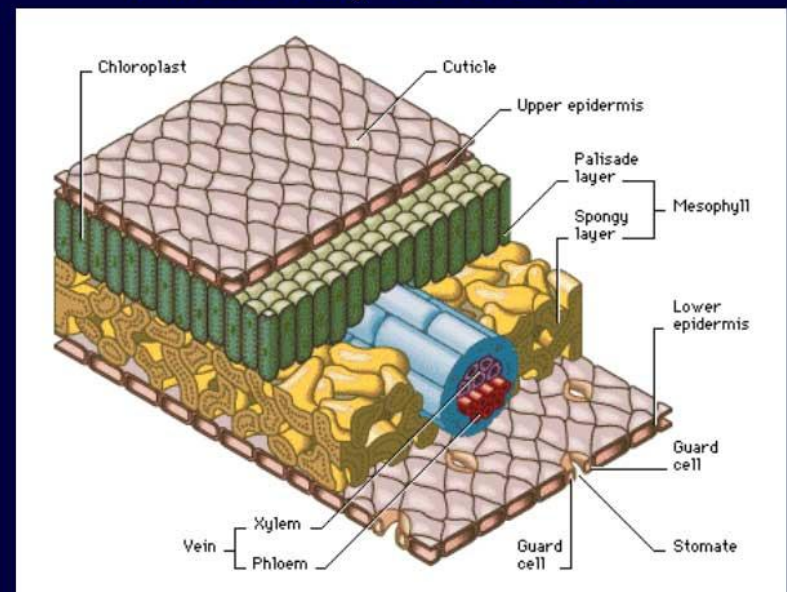

2 Stage Process

- **The Light-Dependent Reaction**

- A chloroplast traps light energy and converts it into chemical energy contained in two types of molecules
 - nicotinamide adenine dinucleotide phosphate (NADP)
 - adenosine triphosphate (ATP)

- **The Light-Independent Reaction**

- NADPH provides the hydrogen atoms that help form glucose,
- ATP provides the energy for this and other reactions used to synthesize glucose

Photosynthesis

- Light energy causes the electrons in chlorophyll to boost up and out of their orbit; the electrons instantly fall back into place, releasing resonance energy, or vibrating energy, as they go, all in millionths of a second.

The Light-Dependent Reaction



The Light-Dependent Reaction

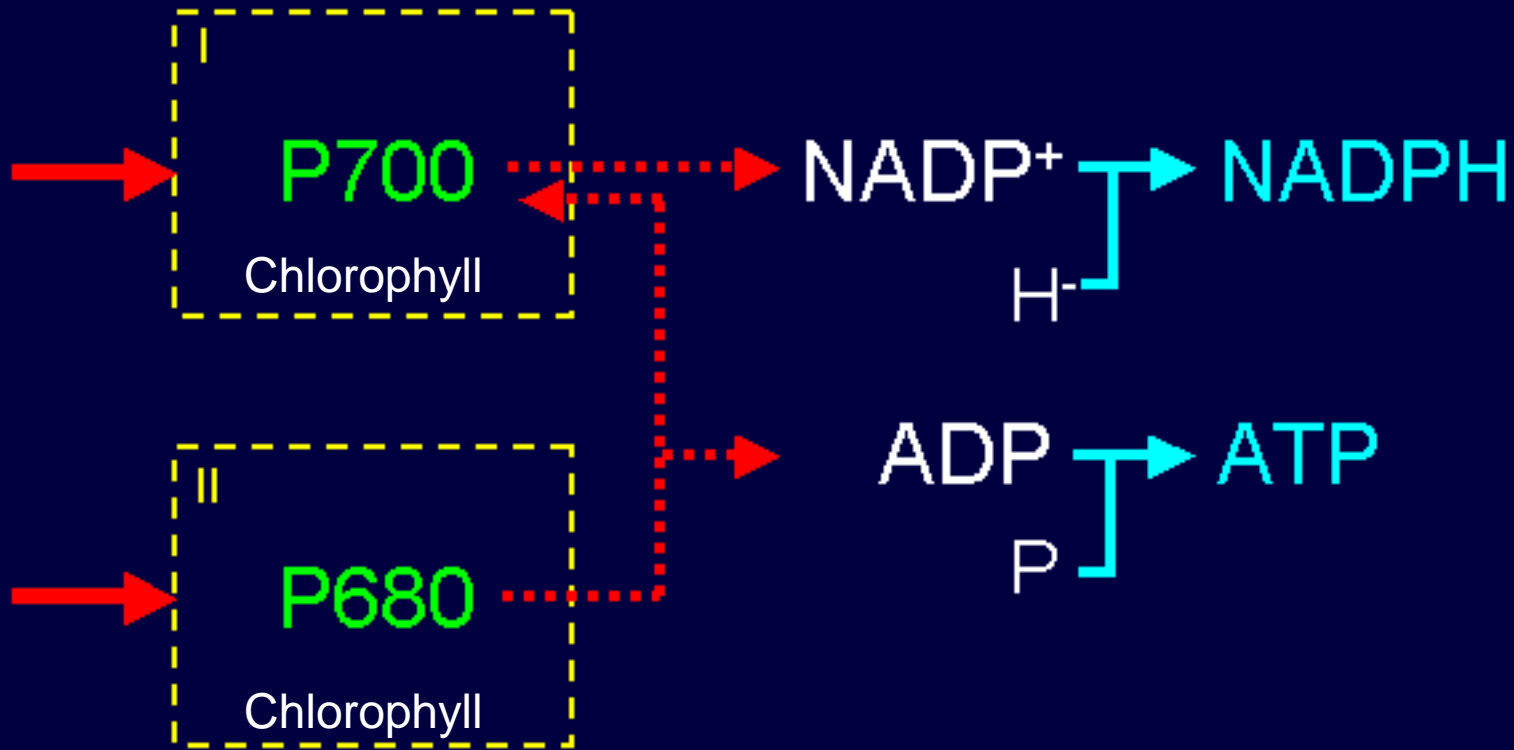

The Light-Dependent Reaction

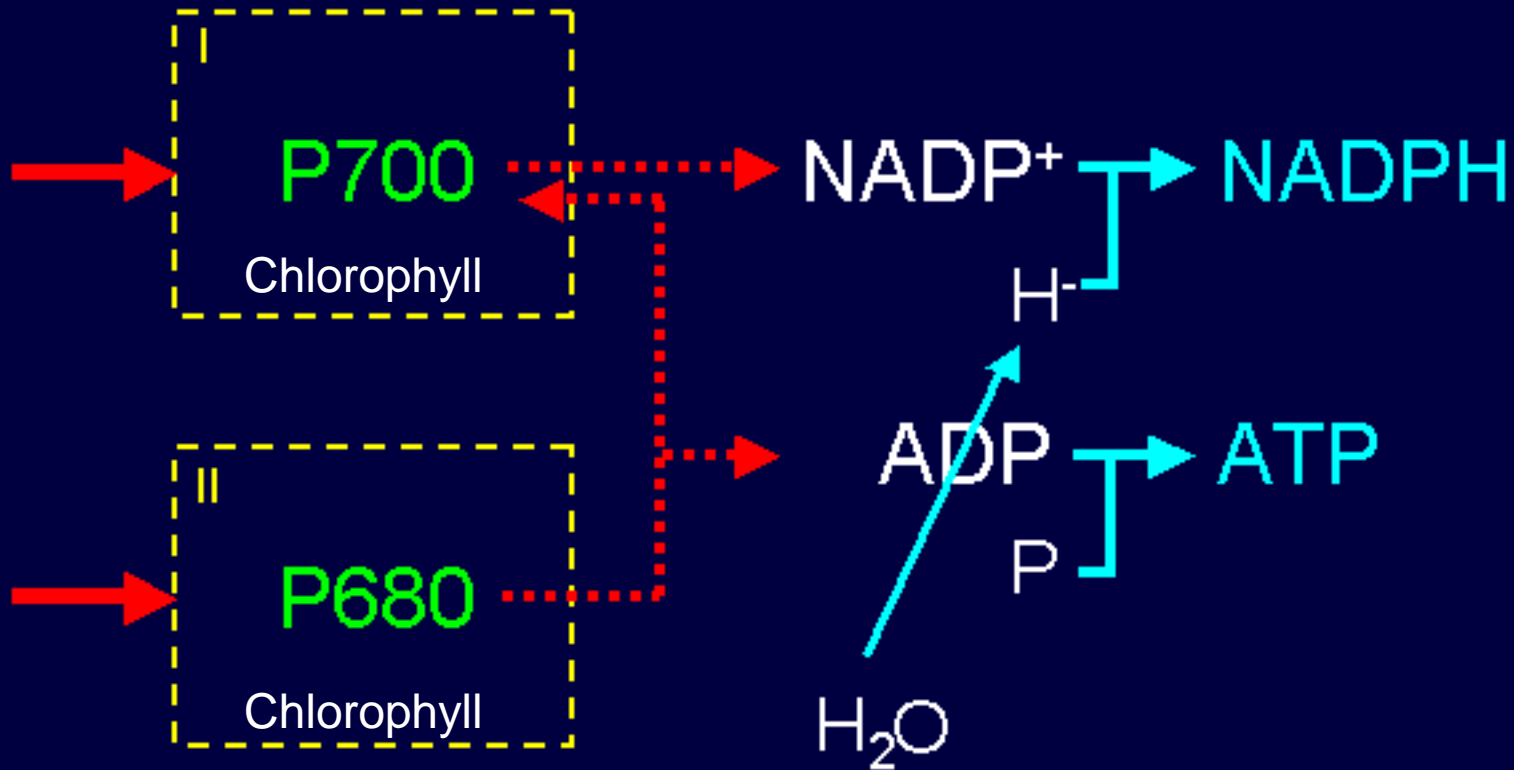

Light-Independent Reaction (Calvin Cycle)

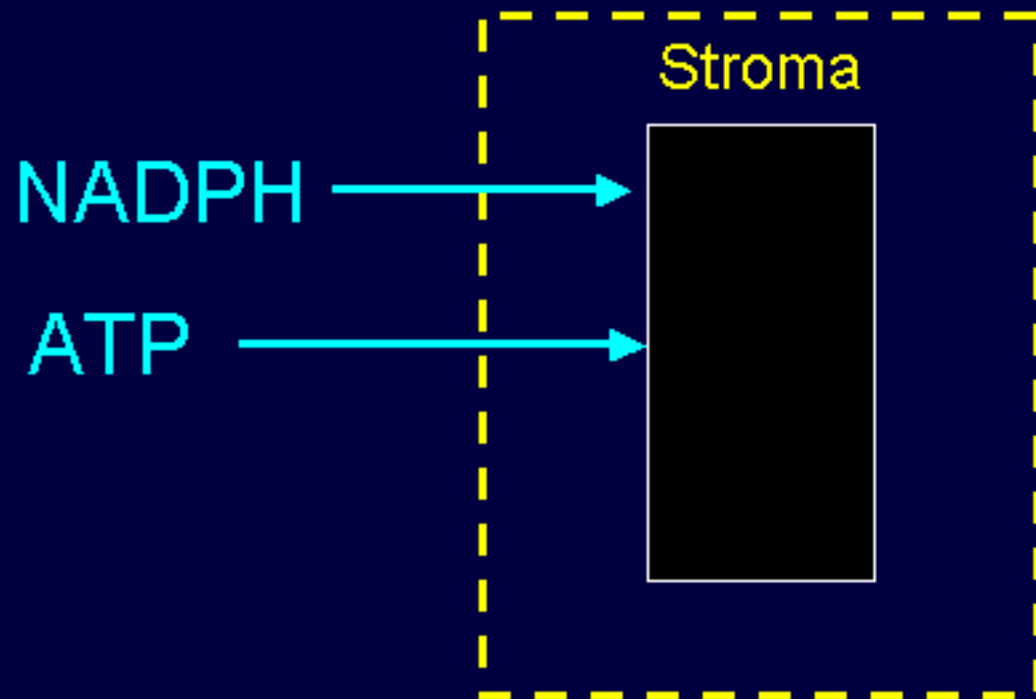

Light-Independent Reaction (Calvin Cycle)

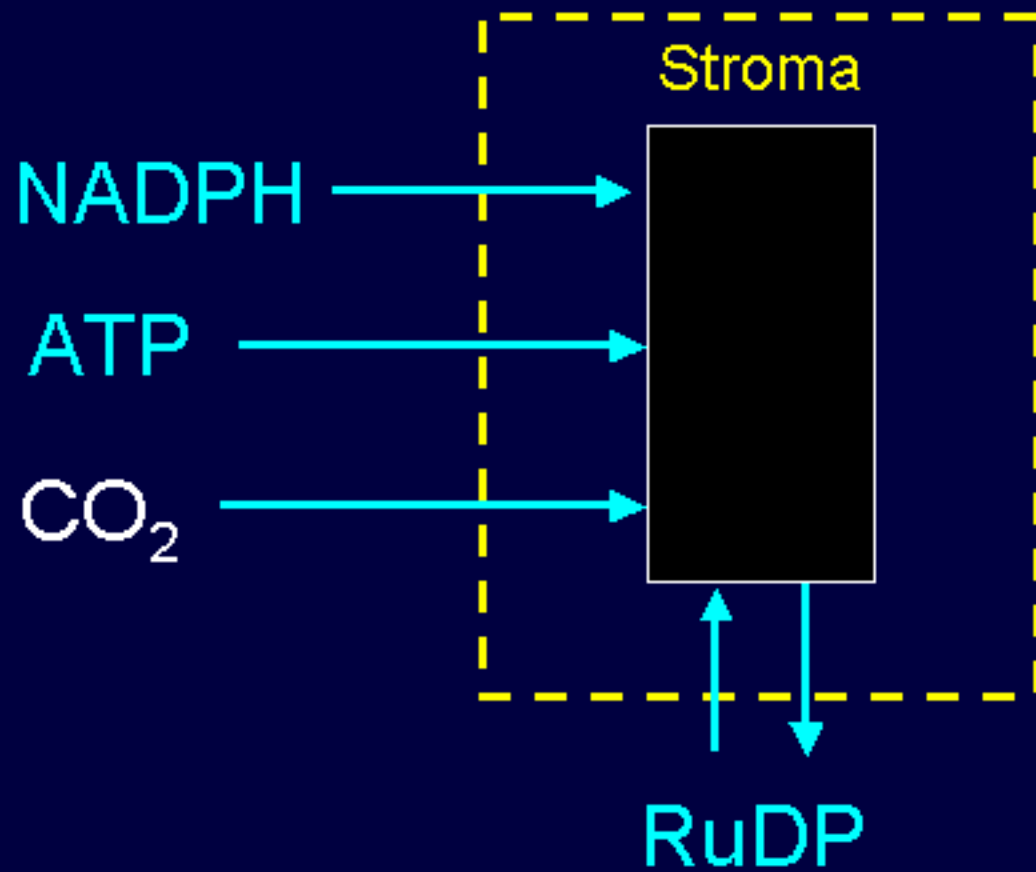

Light-Independent Reaction (Calvin Cycle)

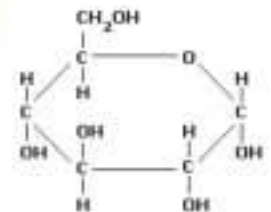
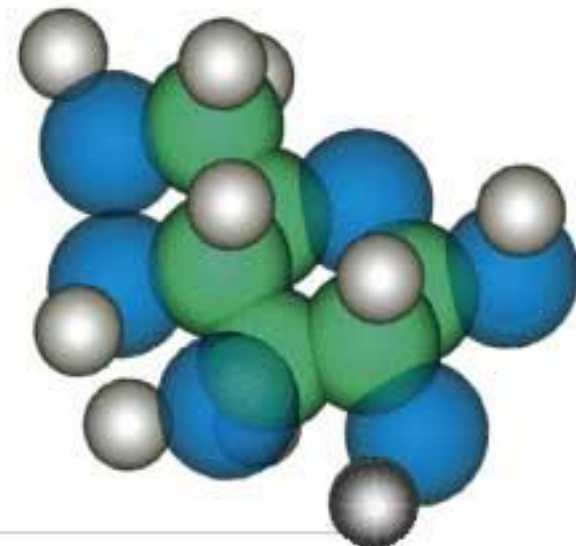
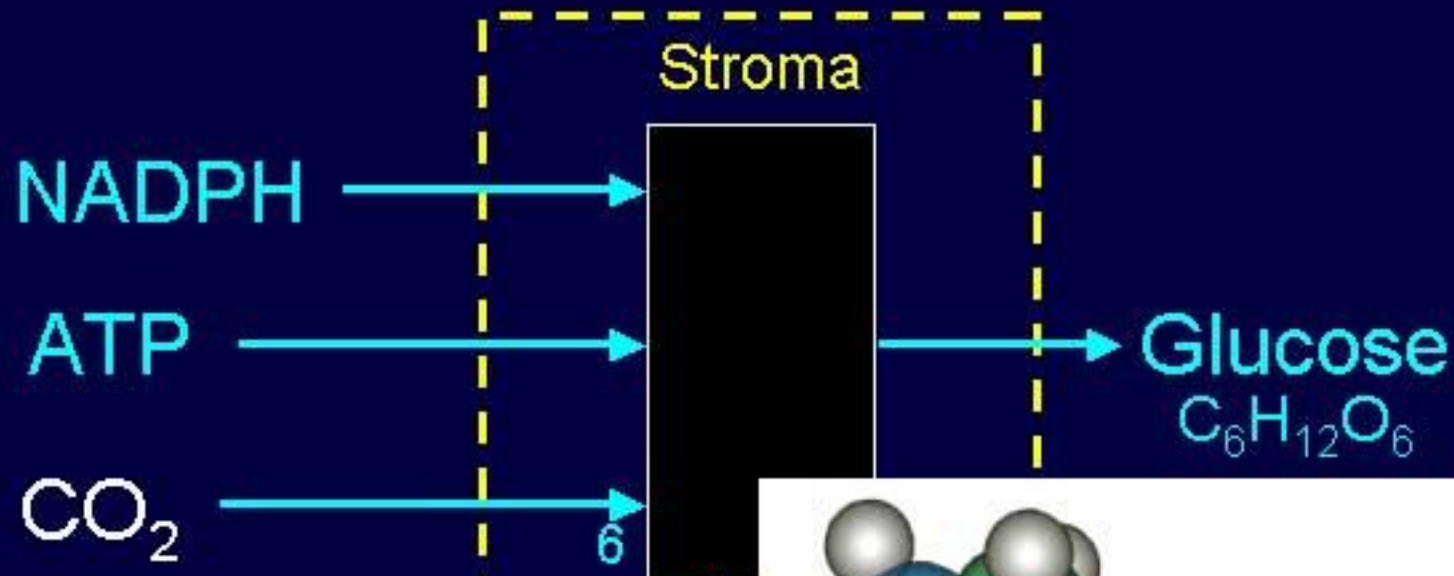

A Simple Leaf?



14 And God said, Let there be lights in the firmament of the heaven to divide the day from the night; and let them be for signs, and for seasons, and for days, and years:

15 And let them be for lights in the firmament of the heaven to give light upon the earth: and it was so.

16 And God made two great lights; the greater light to rule the day, and the lesser light to rule the night: he made the stars also.

17 And God set them in the firmament of the heaven to give light upon the earth,

17 And God set them in the firmament of the heaven to give light upon the earth,

18 And to rule over the day and over the night, and to divide the light from the darkness: and God saw that it was good.

19 And the evening and the morning were the fourth day.

Genesis 1:17-19

- Note: the Sun and Moon are not named!
- These titles were applied much later
- This is good evidence that the Genesis account pre-dates all other 'creation' accounts

²⁰ And God said, Let the waters bring forth abundantly the moving creature **that hath life,** and fowl that may fly above the earth in the open firmament of heaven.

²¹ And God created great whales, and every living creature that moveth, which the waters brought forth abundantly, after their kind, and every winged fowl after his kind: and God saw that it was good.

Genesis 1:20-21

²² And God blessed them, saying, Be fruitful, and multiply, and fill the waters in the seas, and let fowl multiply in the earth.

²³ And the evening and the morning were the fifth day.

Genesis 1:22-23

²⁴ And God said, Let the earth bring forth the living creature **after his kind**, cattle, and creeping thing, and beast of the earth **after his kind:** and it was so.

²⁵ And God made the beast of the earth after his kind, and cattle **after their kind**, and every thing that creepeth upon the earth **after his kind:** and God saw that it was good.

Genesis 1:24-25

²⁶ And God said, Let us make man in our image, after our likeness: and let them have dominion over the fish of the sea, and over the fowl of the air, and over the cattle, and over all the earth, and over every creeping thing that creepeth upon the earth.

²⁷ So God created man in his own image, in the image of God created he him; male and female created he them.

Genesis 1:26-27

- Made in God's image: Body, Soul, Spirit
- Created them?

What About Eve?

²⁷ So God created man in his own image, in the image of God created he him; male and female created he them.

Genesis 1:27

God

In His resemblance

In His resemblance

Man

Alpha & Omega

God

Created out of nothing

אלהים
Eloheim

בצל
tseh-lem

בצלמו
tseh-lem

האדם
adam

את
?

אלהים
Eloheim

ויברא
bara

him

created out of nothing

female

male

him

created out of nothing

אתם:
'eth

ברא
bara

ונקבה
neqebah

זכר
zakar

אתו
'eth

ברא
bara



System Dependencies

- Digestive System
- The Circulatory System
- The Respiratory System
- The Sensory Systems
 - Eyes, Ears, Proprioceptive System
- The Immune System
- The Nervous System

The Human Brain

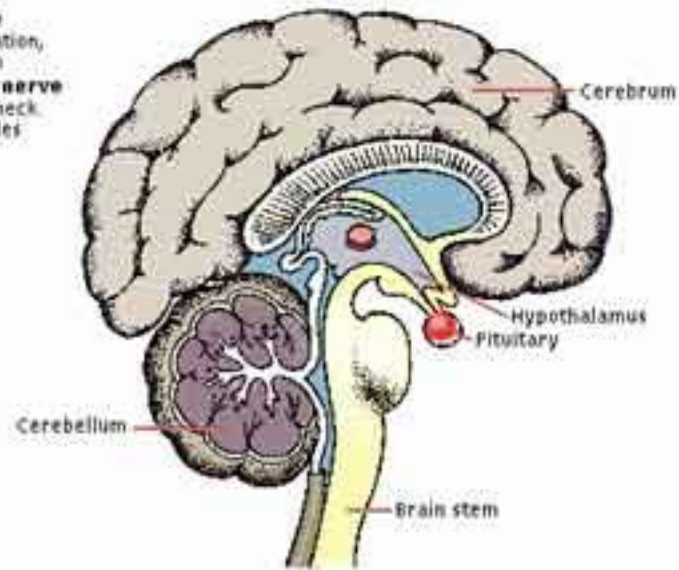
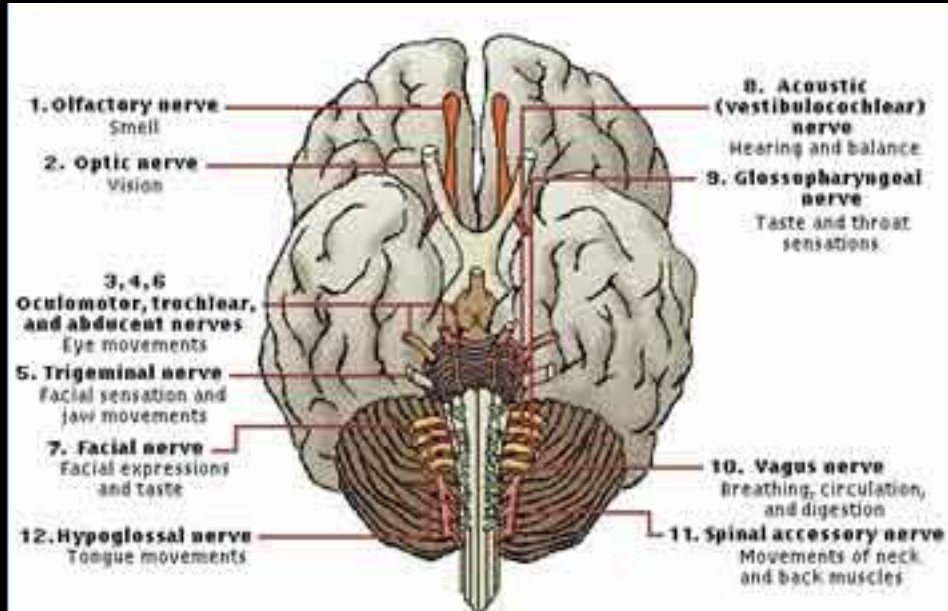

The Human Brain

- 10^{10} nerve cells
- *Each* with 10^4 - 10^5 connecting fibres
- Approaches 10^{15} connections
 - 50,000 leaves/tree
 - 10,000 trees/sq. mile
 - 2 million square miles
 - A Forrest the size of the USA

The Human Brain

- A highly organized network of uniquely adaptive communication channels;
- If only 1% of the connections were specifically organized pathways, it would still represent a greater number of connections than the entire communications network on the Planet Earth.

²⁸ And God blessed them, and God said unto them, Be fruitful, and multiply, and replenish the earth, and subdue it: and have dominion over the fish of the sea, and over the fowl of the air, and over every living thing that moveth upon the earth.

²⁹ And God said, Behold, I have given you every herb bearing seed, which is upon the face of all the earth, and every tree, in the which is the fruit of a tree yielding seed; to you it shall be for meat.

Genesis 1:28-29

Seeds For Food?

We do not do that much anymore. We eat the hamburger, French fries and Coke. God said eat the fruit, the vegetables and the seeds. When you eat the peach, you should eat the seed – inside there is a nut

Inside many seeds there's a vitamin called Vitamin B₁₇. B₁₇ is found in the seeds, not in the fruit and people that get lots of B₁₇ in their diet never get cancer. Have you ever noticed a dog or a cat get sick and go out and eat grass? Certain kinds of grass contain Vitamin B₁₇. Did you know wild animals never get cancer? Zoo animals get it all the time.

Seeds For Food?

The Hunza, a tribe in India, when they [were] first discovered before any white people got into the area, the average age was 165. As they built a highway and people began coming in and out of the area, life spans dropped off to 90 average, still pretty old. Today the average is still 90. Hunza's favorite food is apricot seeds; it just so happens that apricot seeds have more B₁₇ than anything else found in nature. The Hunza's never had a case of cancer ever.

Seeds For Food?

Can a vitamin cure cancer?

Well, for years sailors died of scurvy. What cures scurvy? Vitamin C. After the cure was discovered in 1753, the navy did nothing about it for 50 more years. During that time, one million sailors died in the British navy alone...after the cure was known!

In 1795, they finally admitted Vitamin C cures scurvy.

Seeds For Food?

About White Bread. The Bible says God gave herb for the service of man and bread strengthens man's heart. Bread used to till they started messing with it. Back in the old days when they had to bake bread fresh everyday because it would go bad, nobody had heart attacks. You were more likely to get run over by an aardvark than you were to die of a heart attack. But somebody discovered (and remember, the love of money is the root of all evil) what was making the bread go bad, was the Vitamin E and the Lecithin. So they took those out of the bread and made white bread and now the bread lasts a long time. The people do not, but the bread does! Get more profits! There is a simple formula: the whiter the bread, the quicker you are dead. If it will not go bad in a few days, there is probably nothing in it to go bad which means there is nothing in it that is good for you. Bread strengthens man's heart (Psalm 104:15) — well, used to!

30 And to every beast of the earth, and to every fowl of the air, and to every thing that creepeth upon the earth, wherein there is life, I have given every green herb for meat: and it was so.

31 And God saw every thing that he had made, and, behold, it was very good. And the evening and the morning were the sixth day.

Genesis 1:30-31

¹ Thus the heavens and the earth were finished, and all the host of them.

² And on the seventh day God ended his work which he had made; and he rested on the seventh day from all his work which he had made.

³ And God blessed the seventh day, and sanctified it: because that in it he had rested from all his work which God created and made.

Genesis 2:1-3



The Book of Genesis

Chapter 2

- 4 These are the generations of the heavens and of the earth when they were created, in the day that the LORD God made the earth and the heavens,
- 5 And every plant of the field before it was in the earth, and every herb of the field before it grew: for the LORD God **had not caused it to rain** upon the earth, and there was not a man to till the ground.
- 6 But there went up a mist from the earth, and watered the whole face of the ground.

7 And the LORD God formed man of the dust of the ground, and breathed into his nostrils the breath of life; and man became a living soul.

8 And the LORD God planted a garden eastward in Eden; and there he put the man whom he had formed.

9 And out of the ground made the LORD God to grow every tree that is pleasant to the sight, and good for food; the tree of life also in the midst of the garden, and the tree of knowledge of good and evil.

Genesis 2:7-9

Deliberate supernatural design hidden in the text!

The Trees in Genesis 2

And God said, Behold, I have given you every herb bearing seed, which is upon the face of all the earth, and every tree, in the which is the fruit of a tree yielding seed; to you it shall be for meat...

Genesis 1:29

and ending with

The Trees in Genesis 2

And God said, Behold, I have given you every herb bearing seed, which is upon the face of all the earth, and every tree, in the which is the fruit of a tree yielding seed; to you it shall be for meat...

Genesis 1:29

and ending with

And out of the ground made the LORD God to grow every tree that is pleasant to the sight, and good for food; the tree of life also in the midst of the garden, and the tree of knowledge of good and evil.

Genesis 2:9

Trees in Genesis 2

אשל	Tamarisk (2)	רמון	Pomegranate (8)
אלה	Terebinth, (-2)	גפר	Gopherwood or fir (8)
עבת	Thicket (or Dense forest) (-3)	סנה	Thornbush [<i>Crataegus</i>] (9)
הדר	Citron (-3)	זית	Olive (-9)
שטה	Acacia (-3)	בטן	Pistachio Nut (13)
שקד	Almond (5)	לוז	Hazel (-13)
חטה	Wheat (5)	חאנה	Fig (14)
חמר	Date Palm(5)	ערבה	Willow (-15)
ארז	Cedar (-5)	אלון	Oak (17)
אהלים	Aloe (6)	נפץ	Vine (-18)
ענב	Grape (-6)	שערה	Barley (-28)
אטד	Boxthorn or Bramble (7)	ערמו	Chestnut (44)
קדה	Cassia (7)	לבנה	Poplar (-85)

10 And a river went out of Eden to water the garden; and from thence it was parted, and became into four heads.

11 The name of the first is Pison: that is it which compasseth the whole land of Havilah, where there is gold;

12 And the gold of that land is good: there is bdellium and the onyx stone.

13 And the name of the second river is Gihon: the same is it that compasseth the whole land of Ethiopia.

14 And the name of the third river is Hiddekel: that is it which goeth toward the east of Assyria. And the fourth river is Euphrates.

15 And the LORD God took the man, and put him into the garden of Eden to dress it and to keep it.

Genesis 2:14-15

The Original Greenhouse?



The Original Greenhouse

Water canopy

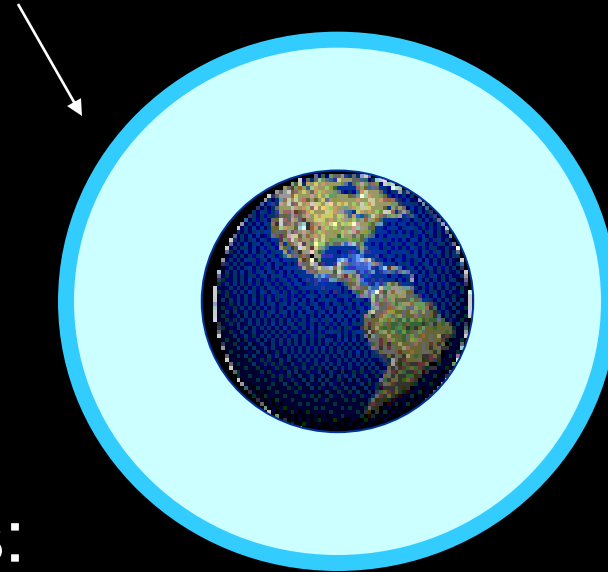

Main Effects:

- Regulate the temperature on earth
 - constant, tropical everywhere
- Increase air pressure
 - more oxygen & carbon dioxide
- Shield from solar radiation
 - Natural protection for life on earth leading to greater lifespans

The Original Greenhouse

Scientific Validation:

- Coal Seams at South Pole
- Frozen Leaves at Poles
- Mammoths found with undigested tropical vegetation still in their stomachs



Time Magazine,
Nov 9, 1987,
p. 82

"50% more oxygen than it does now."

Some research shows it had 35% oxygen.

Putting on Ancient Airs

Dinosaurs, it seems, may have breathed easier than we do. Indeed, at a meeting of the Geological Society of America in Phoenix last week, two scientists stunned colleagues by reporting that 80 million years ago, the earth's atmosphere contained about **50% more oxygen than it does now.** Geochemists Gary Landsis of the U.S. Geological Survey and Robert Berner of Yale reached their startling conclusion after analyzing tiny air bubbles trapped in bits of amber, the aged and solidified resin of coniferous trees. They

placed the amber inside a vacuum chamber, then cracked it to let the ancient air escape. They found that it was 32% oxygen, compared with 21% in the modern atmosphere.

If the findings are accurate, ideas about atmospheric evolution might have to be revised. The two admit the results "are still very preliminary," but they insist the method is sound.

Berner quickly dismisses speculation that a change in the oxygen supply had anything to do with the extinction of dinosaurs. "It was a very slow change, over millions of years," he observes. "And most organisms easily adapt." Next comes testing bubbles in 300 million-year-old amber.



Bubble-bearing amber

The Original Greenhouse

New
not a

BOSTON (AP) —
would have it by a p
... all these kind
... in the auto
... been want
... support their
... respiratory system
... suggest

A new analysis of a
\$20 billion year-old
... rain control. Man
... back on the wor
... dinosaurs survived
... giant asteroid hit the
... million years ago, and
... that killed the
... plants.

Dinosaurs were ab
... way out by the time
... supposedly he, says C
... U.S. Geological Surv
... and ...

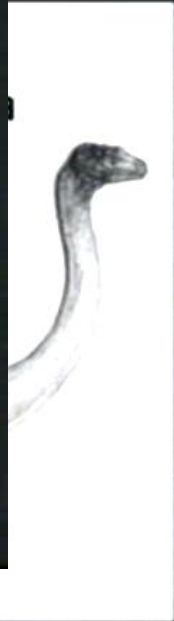

The Original Greenhouse

“...earth’s atmosphere contained about 50% more oxygen than it does today” – *Time Magazine* 9/11/87 p.82

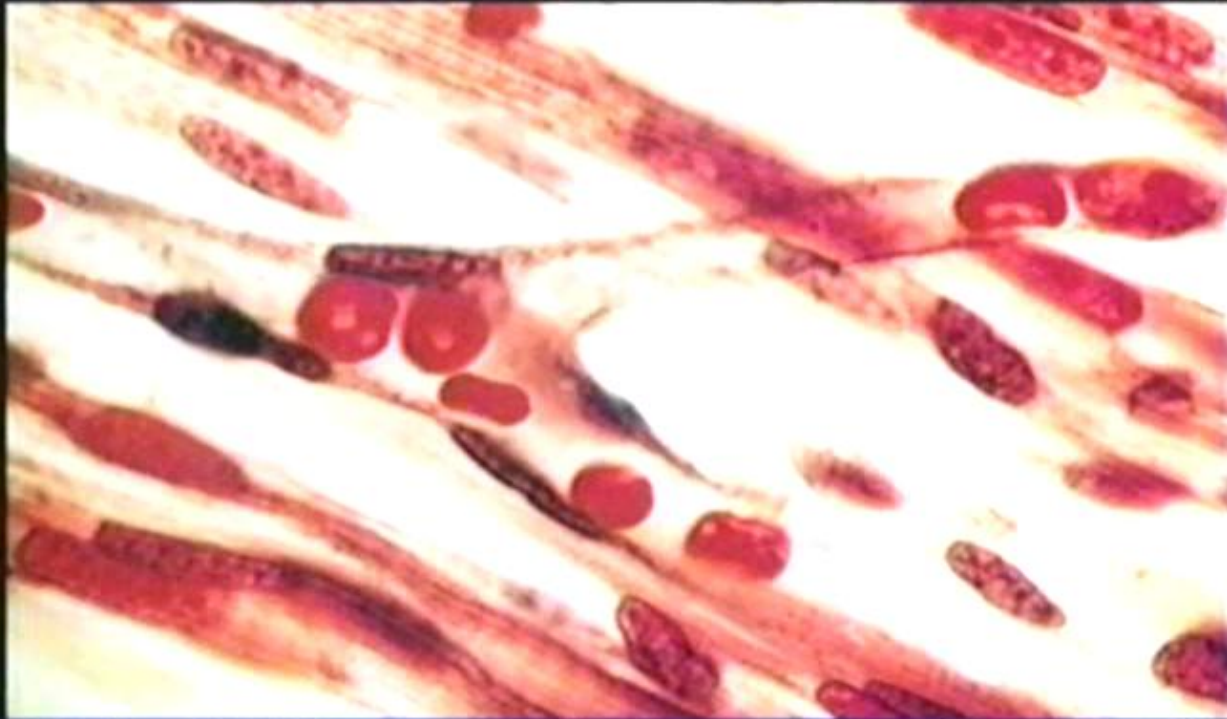

Under double atmospheric pressure plasma will become oxygen saturated.

Hyperbaric Chamber

“Several English football teams used hyperbaric oxygen therapy (HBO3) to treat their players this year, apparently with excellent results. In one case, an athlete with ligament damage reduced recovery time by 33 per cent with hyperbaric oxygen therapy, and a second player receiving hyperbaric oxygen therapy recovered in only four days even though doctors had predicted a three-week lay-off.”

<http://www.sportsinjurybulletin.com/archive/0405-hyperbaric-oxygen.htm>



Hyperbaric Medical Centre – Plymouth
(just 1 of 17 centres in the UK)

The Original Greenhouse

- Fossilised Moss 3ft deep
- Fossils of Asparagus 40ft high
- 50ft Horsetail Reeds found fossilised
- Ferns over 50ft tall
- Fossil cattails 60ft long found in sedimentary rock



The Original Greenhouse

- Dr Mori – grew cherry tomato plants under 2 x air pressure
 - One grew to a height of 16ft tall, producing 907 tomatoes

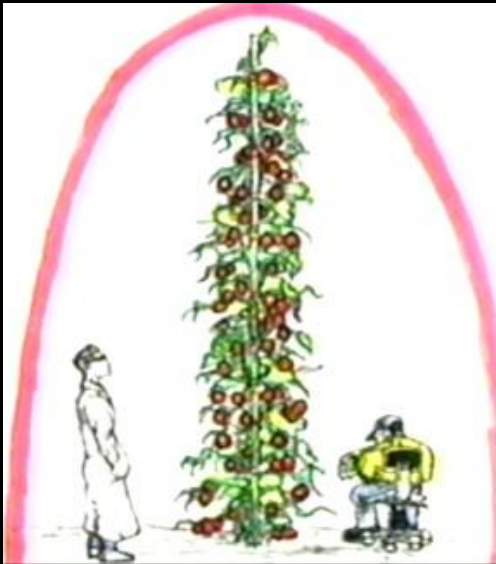

The Original Greenhouse

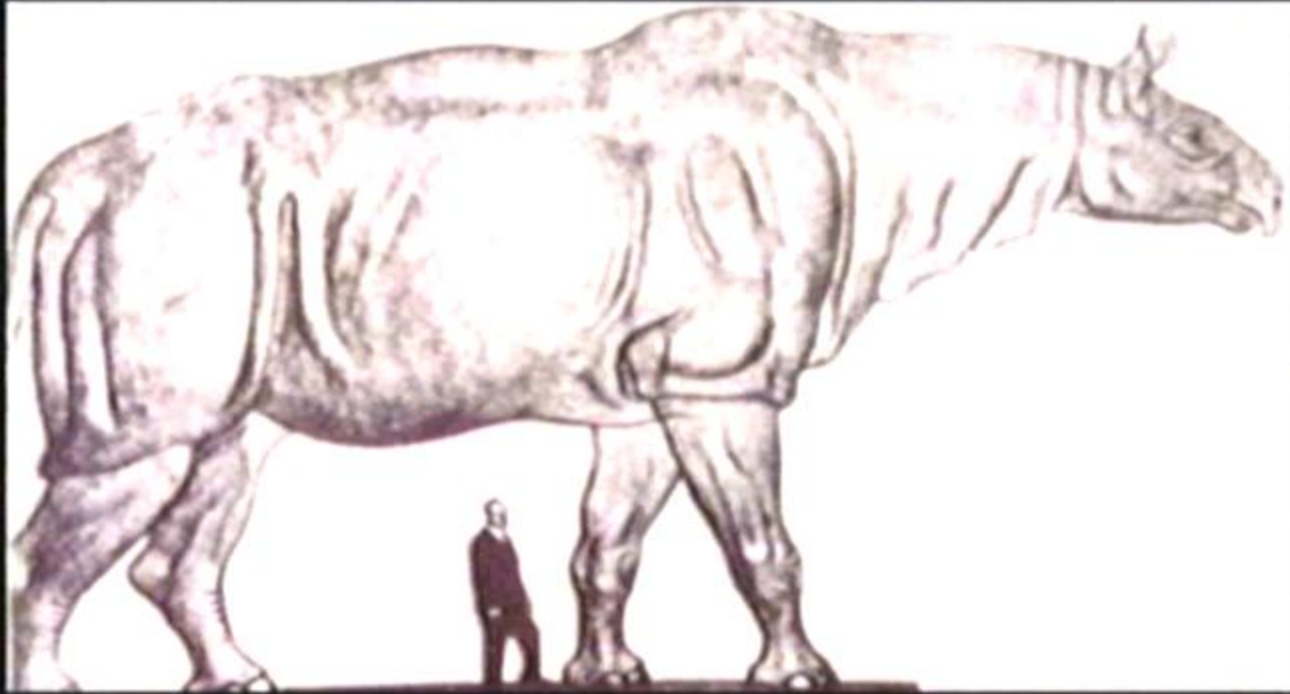

Rhinoceros 18 feet tall

University of Nebraska Museum

The Original Greenhouse

Three foot wingspan

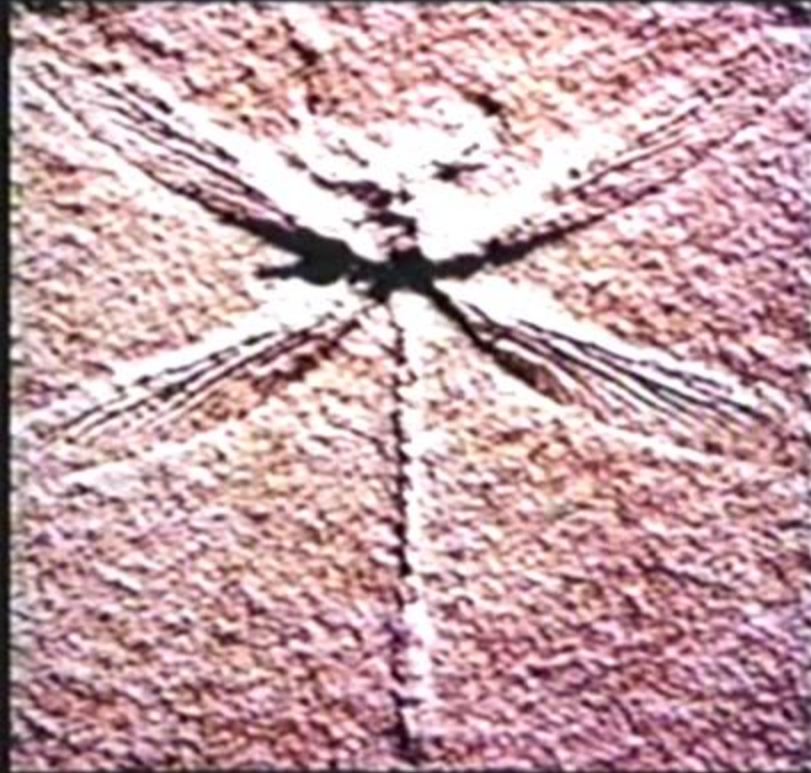

The Original Greenhouse



Cockroaches
over 18
inches
(45cm) long
have been
found in the
fossil
record!

The Original Greenhouse

8ft centipede

The fossil of a centipede measuring eight-and-a-half feet has been discovered by palaeontologists in Thuringen, Germany. The creature existed about 296 million years ago and is claimed to be the largest land-living insect found.

Michael Leidig, Vienna

Aug. 28, 1999 DT

A fossil centipede 8.5 feet (2.6m) long has been found.



The Original Greenhouse

Fossils of grasshoppers over 2 feet long (60cm) have been found.



The Original Greenhouse

A donkey was excavated near Lubbock, Texas that was **9 feet** (2.75 m) high at the shoulder!

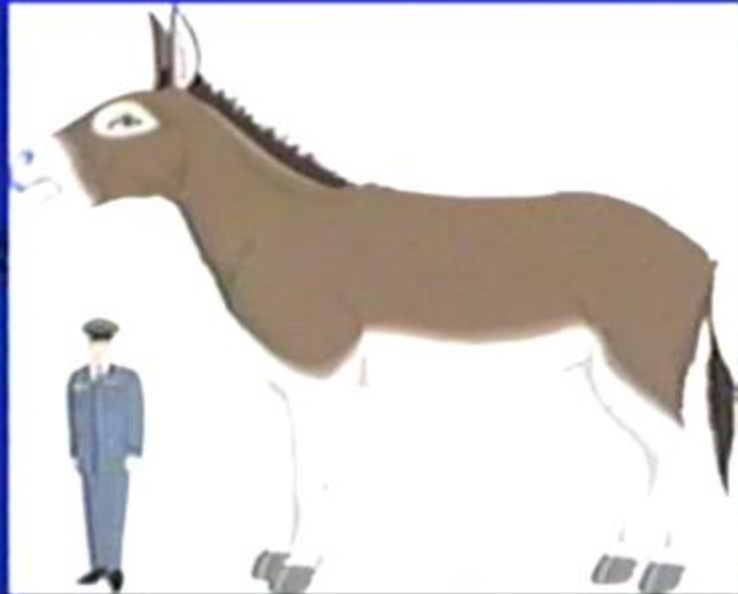

The Original Greenhouse

**Fossil Buffalo horns have
been found with a 12
foot span!**

**8 foot horn core
is in Dr. Baugh's
museum.**

Geologist

Don Patton

972-279-5325



The Original Greenhouse

Fossils of beavers over
8 feet long (2.4 m)
have been found.



The Original Greenhouse



The Original Greenhouse

“The biggest pterosaur flying over the inland sea is Pteranodon. Like all reptiles, it grows throughout its life...”

Holt Earth Science, 1991, p. 293

The Original Greenhouse



The Original Greenhouse



The Original Greenhouse



The Original Greenhouse

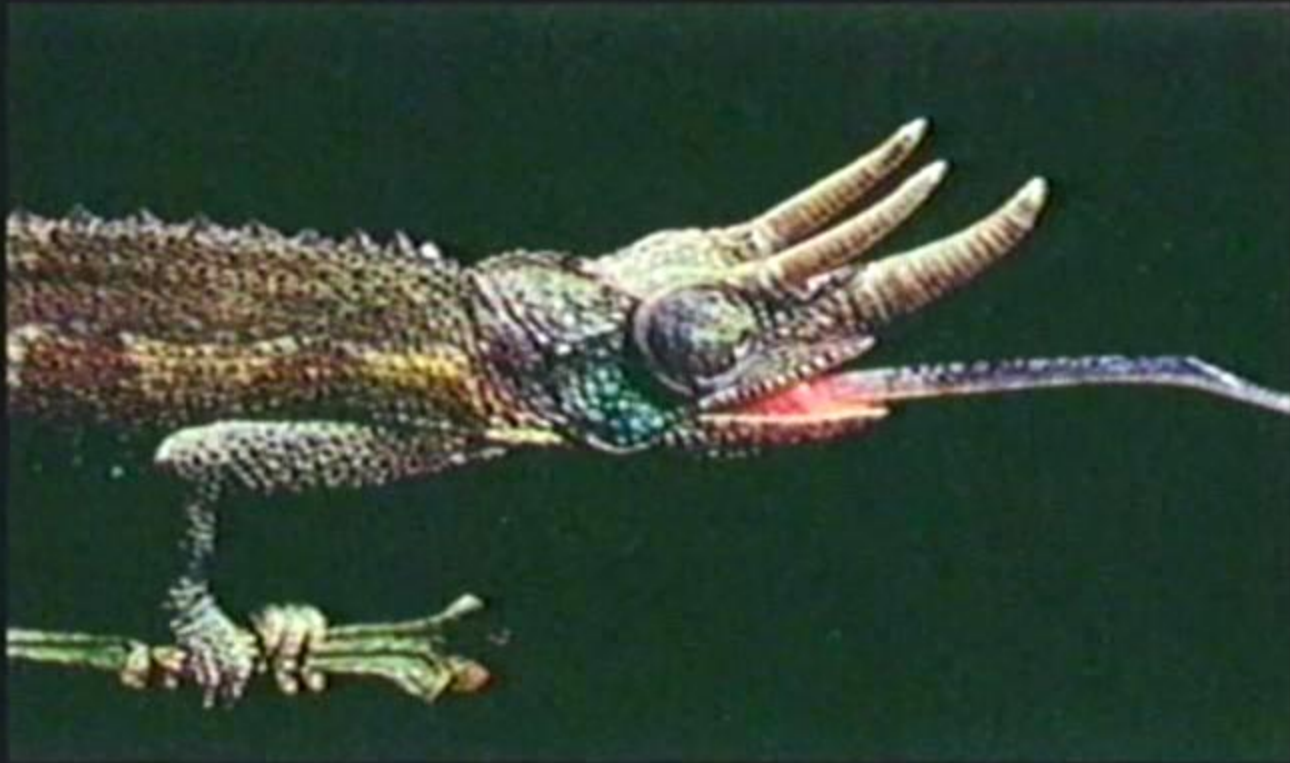

The Original Greenhouse

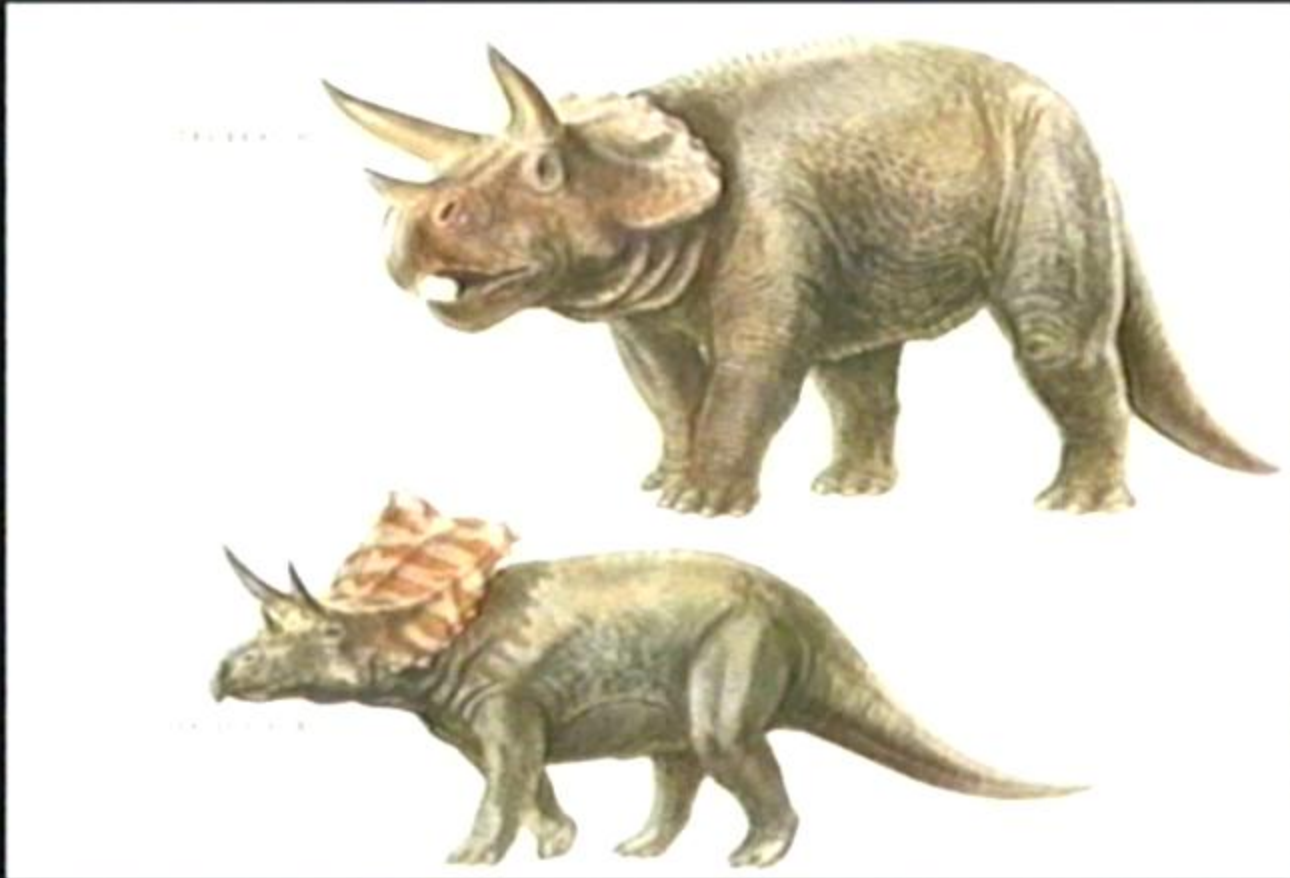

Radiation

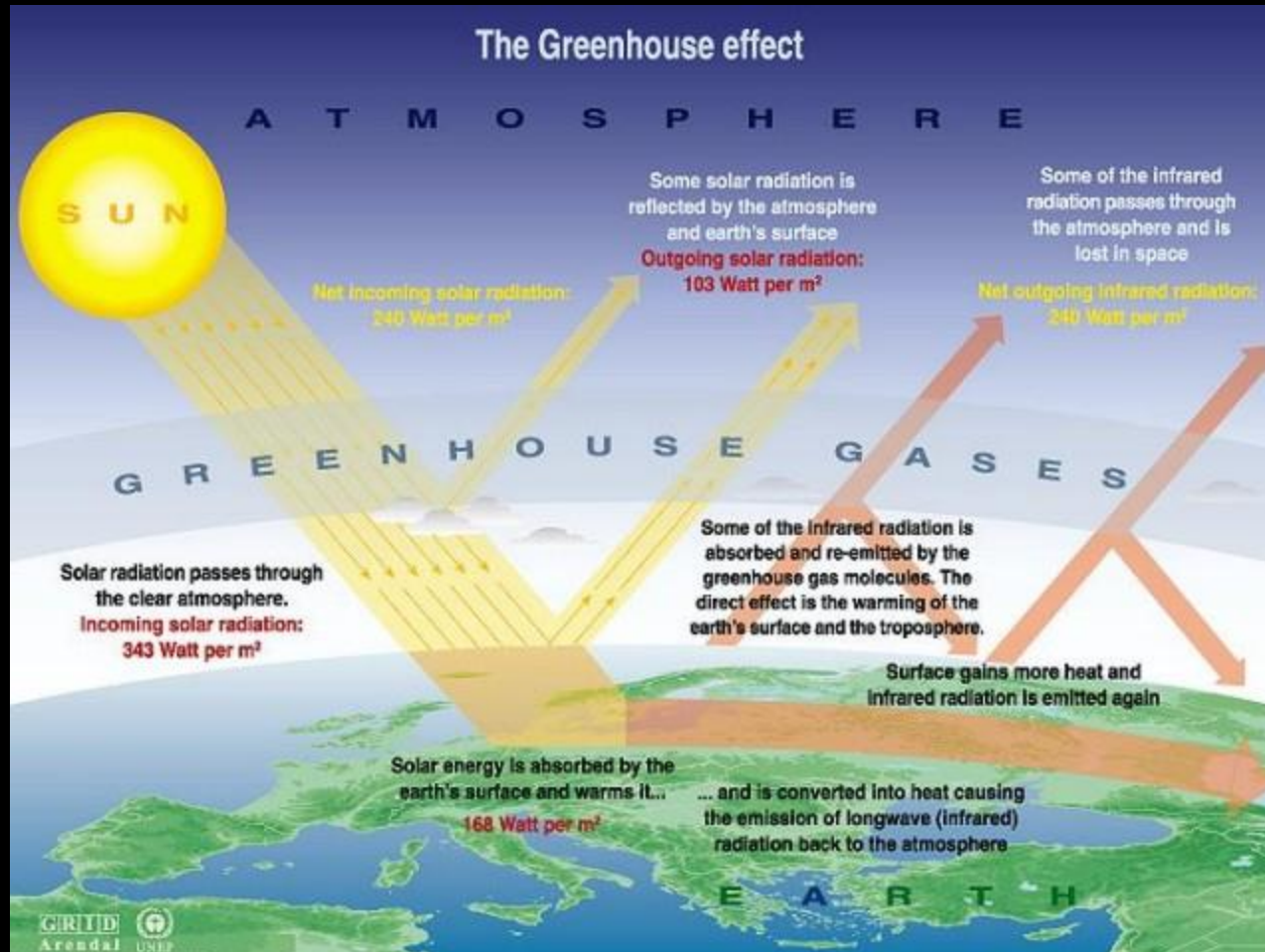

Radiation

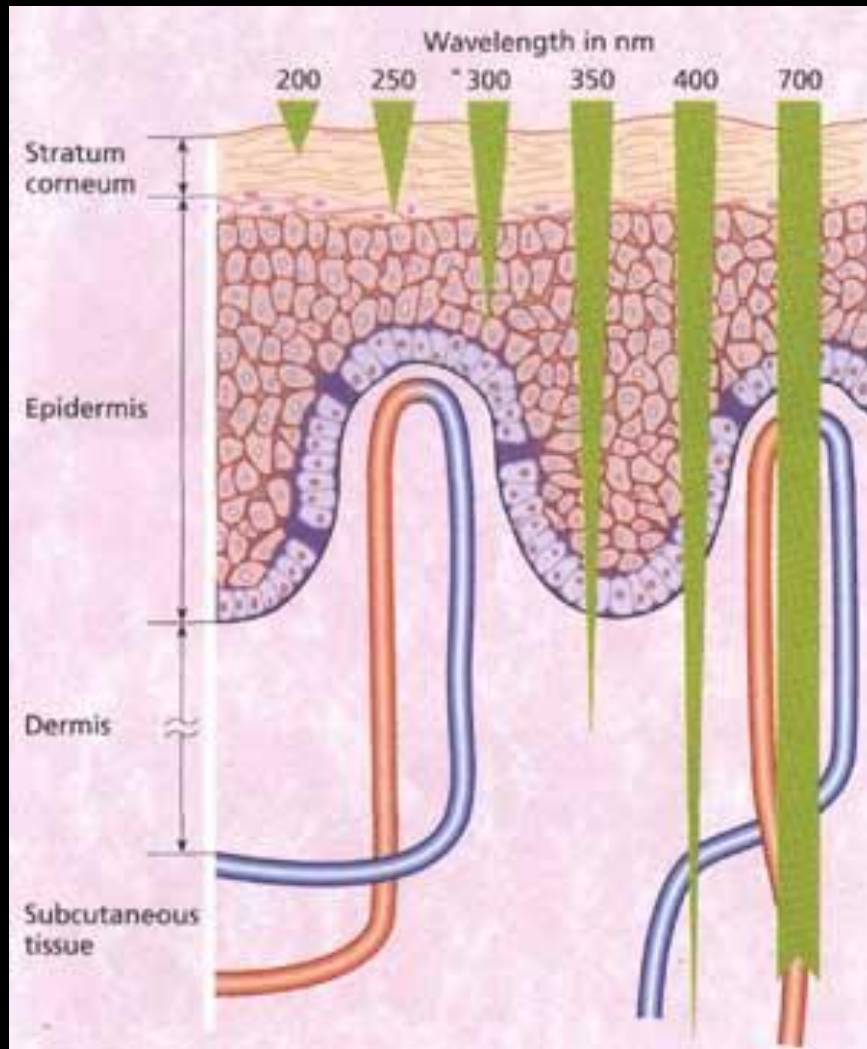

Our Skin

Pre-Flood World

- More Oxygen
 - it would have been fun just to breath!
 - people would have grown more / been fitter
- Stable Climate
 - No cold winters
- Water canopy acting as radiation shield
 - Assists longevity
- No junk food yet!
 - People eating the food God had made

*16 And the LORD God commanded the man, saying,
Of every tree of the garden thou mayest freely eat:*

*17 But of the tree of the knowledge of good and evil,
thou shalt not eat of it: for in the day that thou eatest
thereof thou shalt surely die.*

Genesis 2:14-17

- Where was Eve?
- Not yet created!
- God leaves the responsibility to teach Eve to Adam!

Man's Help Meet

¹⁸ And the LORD God said, It is not good that the man should be alone; I will make him an help meet for him.

Gen 2:18

- ‘Help Meet’ – *‘Helper suitable’*
- Marriage instituted – v.24 (quoted by Jesus)
 - *Heterosexual*
 - *Monogamous*
 - *For life*
- The Mystical Purpose of Marriage – Eph 5:22-32

4 And he answered and said unto them, Have ye not read, that he which made them **at the beginning** made them male and female,

Matthew 19:4

- God made man and woman at the beginning!
 - No room for evolution!
 - Jesus took Genesis 1-2 literally
 - Explain the origin of the sexes without Genesis!

19 And out of the ground the LORD God formed every beast of the field, and every fowl of the air; and brought them unto Adam to see what he would call them: and whatsoever Adam called every living creature, that was the name thereof.

20 And Adam gave names to all cattle, and to the fowl of the air, and to every beast of the field; but for Adam there was not found an help meet for him.

Genesis 2:18-20

- Adam is left in no doubt that God is Creator!

21 And the LORD God caused a deep sleep to fall upon Adam and he slept: and he took one of his ribs, and closed up the flesh instead thereof;

22 And the rib, which the LORD God had taken from man, made he a woman, and brought her unto the man.

Genesis 2:21-22

²³ And Adam said, This is now bone of my bones, and flesh of my flesh: she shall be called Woman, because she was taken out of Man.

²⁴ Therefore shall a man leave his father and his mother, and shall cleave unto his wife: and they shall be one flesh.

²⁵ And they were both naked, the man and his wife, and were not ashamed.

Genesis 2:23-25

²³ And Adam said, This is now bone of my bones, and flesh of my flesh: she shall be called Woman, because she was taken out of Man.

²⁴ Therefore shall a man leave his father and his mother, and shall cleave unto his wife: and they shall be one flesh.

²⁵ And they were both naked, the man and his wife, and were not ashamed.

Genesis 2:23-25

5 And said, For this cause shall a man leave father and mother, and shall cleave to his wife: and they twain shall be one flesh?

6 Wherefore they are no more twain, but one flesh. What therefore God hath joined together, let not man put asunder.

Matthew 19:5-6

- The mystical union between a man & wife
- This speaks of Christ and the Church

Man's Duty

- Adam (not Eve) given the warning about the tree – Gen 1:17
- Eve did not witness the Creative acts of God – Gen 1:19
- God holds the Man responsible for his family – Gen 3:9
- Eve had not been properly taught the Word of God – Gen 3:3
 - Throughout scripture it is reiterated that it is man's responsibility to teach his family concerning God

Genesis Chapter 3

The Fall of Man

The Seed Plot of the Bible

The Vendetta

^I Now the serpent was more subtil than any beast of the field which the LORD God had made. And he said unto the woman, Yea, hath God said, Ye shall not eat of every tree of the garden?

Gen 3:1

- ‘Serpent’ = Nachash **והנחש** ‘The Shining One’
- Adam made in the image of (like) God – **Gen 1:26**
- Satan (Lucifer) was the ‘anointed Cherub’ – **Ezek 28:14**
- Satan’s sin was pride – **1 Tim 3:6**
- Satan wanted to be ‘like God’ – **Isaiah 14:14**

The Vendetta

^I Now the serpent was more subtil than any beast of the field which the LORD God had made. And he said unto the woman, Yea, hath God said, Ye shall not eat of every tree of the garden?

Gen 3:1

- ‘Subtle’ = Aruwm ערום ‘wise, full of wisdom, prudent’
- Satan goes for the weak part of our flesh
- Satan exploits a lack of understanding of God’s Word
- Satan’s principle attack is to make us doubt God’s Word
- Satan’s calls into question God’s character

Eve's Response

² And the woman said unto the serpent, We may eat of the fruit of the trees of the garden:

³ But of the fruit of the tree which is in the midst of the garden, God hath said, Ye shall not eat of it, neither shall ye touch it, lest ye die.

Gen 3:2-3

- Revelation 22:18 / Proverbs 30:6 ...*do not add!*
- Lack of humility? – why not go get Adam?

Deception

4 And the serpent said unto the woman, Ye shall not surely die:

5 For God doth know that in the day ye eat thereof, then your eyes shall be opened, and ye shall be as gods, knowing good and evil.

Gen 3:4-5

- Phase 1: Causing to doubt God's word
- Phase 2: Bold and outright lie to cause uncertainty
 - *Why not go get Adam at this point?*
- Phase 3: 'Dangling the carrot'

Deciphering Deception

The Lie:

“As a Christian you can’t do _____, you’re missing out”

“God just doesn’t want you to have fun”

The Truth:

“I don’t need to experience _____ to have the fullness of life that God intends for me.”

NB: You cannot control sin

Where is the Fruit?

16 Know ye not, that to whom ye yield yourselves servants to obey, his servants ye are to whom ye obey; whether of sin unto death, or of obedience unto righteousness?

Romans 6:16

21 What fruit had ye then in those things whereof ye are now ashamed?

Romans 6:21

Eve's Reaction

6 And when the woman saw that the tree was good for food, and that it was pleasant to the eyes, and a tree to be desired to make one wise, she took of the fruit thereof, and did eat, and gave also unto her husband with her; and he did eat.

Gen 3:6

Eve's Reaction

⁶ And when the woman saw that the tree was **good for food**, and that it was pleasant to the eyes, and a tree to be desired to make one wise, she took of the fruit thereof, and did eat, and gave also unto her husband with her; and he did eat.

Gen 3:6

Eve's Reaction

⁶ And when the woman saw that the tree was **good for food**, and that it was **pleasant to the eyes**, and a tree to be desired to make one wise, she took of the fruit thereof, and did eat, and gave also unto her husband with her; and he did eat.

Gen 3:6

Eve's Reaction

⁶ And when the woman saw that the tree was **good for food**, and that it was **pleasant to the eyes**, and a tree **to be desired to make one wise**, she took of the fruit thereof, and did eat, and gave also unto her husband with her; and he did eat.

Gen 3:6

Eve's Reaction

15 Love not the world, neither the things that are in the world. If any man love the world, the love of the Father is not in him.

16 For all that is in the world, the lust of the flesh, and the lust of the eyes, and the pride of life, is not of the Father, but is of the world.

17 And the world passeth away, and the lust thereof: but he that doeth the will of God abideth for ever.

1 John 2:15-17

Self becomes king

7 And the eyes of them both were opened, and they knew that they were naked; and they sewed fig leaves together, and made themselves aprons.

Gen 3:7

- Religion introduced – man's attempt to cover sin
- Fig Leaves:
 - Church going
 - Religious exercises
 - Good works

The Origin of Satan

Ezekiel 28 – When did Satan fall?

Isaiah 14 – Why did Satan fall?

When Did Satan Fall?

Son of man, take up a lamentation upon the king of Tyrus, and say unto him, Thus saith the Lord GOD; Thou sealest up the sum, full of wisdom, and perfect in beauty. Thou hast been in Eden the garden of God; every precious stone was thy covering, the sardius, topaz, and the diamond, the beryl, the onyx, and the jasper, the sapphire, the emerald, and the carbuncle, and gold: the workmanship of thy tabrets and of thy pipes was prepared in thee in the day that thou wast created.

When Did Satan Fall?

Son of man, take up a lamentation upon the king of Tyrus, and say unto him, Thus saith the Lord GOD; Thou sealest up the sum, full of wisdom, and perfect in beauty. Thou hast been in Eden the garden of God; every precious stone was thy covering, the sardius, topaz, and the diamond, the beryl, the onyx, and the jasper, the sapphire, the emerald, and the carbuncle, and gold: the workmanship of thy tabrets and of thy pipes was prepared in thee in the day that thou wast created.

When Did Satan Fall?

Thou art the anointed cherub that covereth; and I have set thee so: thou wast upon the holy mountain of God; thou hast walked up and down in the midst of the stones of fire. Thou wast perfect in thy ways from the day that thou wast created, till iniquity was found in thee. By the multitude of thy merchandise they have filled the midst of thee with violence, and thou hast sinned: therefore I will cast thee as profane out of the mountain of God: and I will destroy thee, O covering cherub, from the midst of the stones of fire.

When Did Satan Fall?

Thine heart was lifted up because of thy beauty, thou hast corrupted thy wisdom by reason of thy brightness: I will cast thee to the ground, I will lay thee before kings, that they may behold thee.

Ezek 28:17

Why Did Satan Fall?

How art thou fallen from heaven, O Lucifer, son of the morning! how art thou cut down to the ground, which didst weaken the nations! For thou hast said in thine heart, **I will** ascend into heaven, **I will** exalt my throne above the stars of God: **I will** sit also upon the mount of the congregation, in the sides of the north: **I will** ascend above the heights of the clouds; **I will** be like the most High. Yet thou shalt be brought down to hell, to the sides of the pit.

'I will be like' = damah' (daw-maw');
a primitive root; to compare; by implication,
to resemble, liken, consider:
KJV - compare, devise, (be) like (-n), mean,
think, use similitudes.

Isaiah 14:12-15

The Greatest Sin?

[A Bishop] - Not a novice, lest being lifted up with pride he fall into the condemnation of the devil.

1 Tim 3:6

The Greatest Sin?

Yea, all of you be subject one to another, and be clothed with humility: for God resisteth the proud, and giveth grace to the humble.

1 Peter 5:5

Every one that is proud in heart is an abomination to the LORD:

Prov 16:5

Adam as a Type of Christ

- “Son of God” Luke 4:38
- Adam was not deceived 1 Tim 2:14
- “Figure of Him...to come” Rom 5:14
- Means of salvation to Eve
 - “Made sin” for her 2 Cor 5:21
- Kinsman required Rev 5
- Church = “Bride” Isa 62:5;
2 Cor 11:2;
Rev 21:2; 22:17

Where Can I Go...? (Psalm 139)

⁸ And they heard the voice of the LORD God walking in the garden in the cool of the day: and Adam and his wife hid themselves from the presence of the LORD God amongst the trees of the garden.

⁹ And the LORD God called unto Adam, and said unto him, Where art thou?

¹⁰ And he said, I heard thy voice in the garden, and I was afraid, because I was naked; and I hid myself.

The Consequence of Guilt

11 And he said, Who told thee that thou wast naked? Hast thou eaten of the tree, whereof I commanded thee that thou shouldest not eat?

12 And the man said, The woman whom thou gavest to be with me, she gave me of the tree, and I did eat.

13 And the LORD God said unto the woman, What is this that thou hast done? And the woman said, The serpent beguiled me, and I did eat.

God Declares War!

14 And the LORD God said unto the serpent, Because thou hast done this, thou art cursed above all cattle, and above every beast of the field; upon thy belly shalt thou go, and dust shalt thou eat all the days of thy life:

15 And I will put enmity between thee and the woman, and between thy seed and her seed; [He] shall [crush] thy head, and thou shalt bruise his heel.

Gen 3:14-15

The Stratagems of Satan

- Corruption of Adam's line Gen 6
- Abraham's seed Gen 12, 20
- Famine Gen 50
- Destruction of male line Ex 1
- Pharaoh's pursuit Ex 14
- The populating of Canaan Gen 12:6
- Against David's line 2 Sam 7

Attacks on David's Line

- Jehoram kills his brothers 2 Chr. 21
- Arabians slew all (but Ahazariah)
- Athaliah kills all (but Joash) 2 Chr. 22
- Hezekiah assaulted, etc. Isa 36, 38
- Haman's attempts Est 3

New Testament Strategems

- Joseph's fears: Matt 1; Deut 24:1
- Herod's attempts: Matt 2
- Attempts at Nazareth: Luke 4
- 2 storms on the Sea: Mark 4; Luke 8
- The Cross
 - "Bruised for our iniquities" Isa 53

New Testament Strategems

- Joseph's fears: Matt 1; Deut 24:1
- Herod's attempts: Matt 2
- Attempts at Nazareth: Luke 4
- 2 storms on the Sea: Mark 4; Luke 8
- The Cross
 - "Bruised for our iniquities" Isa 53
- Summary: Rev 12
 - ...and he's not through...

The Curse - Woman

¹⁶ Unto the woman he said, I will greatly multiply thy sorrow and thy conception; in sorrow thou shalt bring forth children; and thy desire shall be to thy husband, and he shall rule over thee.

Gen 3:16

The Curse - Man

17 And unto Adam he said, Because thou hast hearkened unto the voice of thy wife, and hast eaten of the tree, of which I commanded thee, saying, Thou shalt not eat of it: cursed is the ground for thy sake; in sorrow shalt thou eat of it all the days of thy life;

18 Thorns also and thistles shall it bring forth to thee; and thou shalt eat the herb of the field;

19 In the sweat of thy face shalt thou eat bread, till thou return unto the ground; for out of it wast thou taken: for dust thou art, and unto dust shalt thou return.

He Became a Curse

13 Christ hath redeemed us from the curse of the law, being made a curse for us: for it is written, Cursed is every one that hangeth on a tree:

Galatians 3:13

Two Trees, Two Gardens

- The tree of the knowledge of good and evil
 - where man's problem began
- The 'Tree' on Calvary's hill
 - where man's problem was solved

- The Garden of Eden
 - where the battle of will was conceded
- The Garden of Gethsemane
 - the place where the battle of will was won

The First Sacrifice

20 And Adam called his wife's name Eve; because she was the mother of all living.

21 Unto Adam also and to his wife did the LORD God make coats of skins, and clothed them.

Gen 3:20-21

II For the life of the flesh is in the blood: and I have given it to you upon the altar to make an atonement for your souls: for it is the blood that maketh an atonement for the soul.

Lev 17:11

The Way to the Tree of Life

²² And the LORD God said, Behold, the man is become as one of us, to know good and evil: and now, lest he put forth his hand, and take also of the tree of life, and eat, and live for ever:

²³ Therefore the LORD God sent him forth from the garden of Eden, to till the ground from whence he was taken.

Gen 3:22-23

The Way to the Tree of Life

שֹׁכֵן shâkan

Dwelt x89

²⁴ So he drove out the man; and he placed at the east of the garden of Eden Cherubims, and a flaming sword which turned every way, to keep the way of the tree of life.

Gen 3:24

“God dwelt east of the Garden of Eden, between the Cherubim, as a tongue of fire, to keep open the way to the tree” – Jerusalem Targum

“The Way...” – Acts 9:2; 16:17; 18:25; 26; 19:9 et al

'Between' the Cherubim



The Scarlet Thread Begins

- From the Seed of the Woman Gen 3
- The Call of Abraham Gen 12
- The Tribe of Judah Gen 49
- The Dynasty of David 2 Sam 7
- The Virgin Birth in Bethlehem Isa 7

- To another tree...
 ... in another garden



Next Session

- Satan launches a full scale attack
 - The 1st murder
- Satan launches 2nd assault
 - Wickedness goes off the scale
 - God interviews to save humanity
- Satan launches 3rd assault
 - 3 pronged attack
- God regains the initiative & unveils His recovery plan

The Central Theme

- The OT is an account of a Nation.
- The NT is the account of a Man.
- The Creator became a Man. His appearance is the Central Event of all history.
- He died to purchase us and is alive now.
- The most exalted privilege is to know Him. That's what the Bible is all about.



www.calvaryportsmouth.co.uk